

Feature Summary:

- +/- 5 degrees of rotation
- Class 5 preloaded precision ball-screw with a brushless motor drivetrain for high precision.
- Resolution to 0.12 arc-seconds
- Precision cross-roller bearings deliver high capacity, excellent rigidity and long life.
- Very stiff rotational correction stage for heavy payloads

Overview

Primatics PLR350 Series rotary positioning tables offer a variety of options for systems in need of small, stiff angular corrections. An innovative drive system creates arc-second accuracy and fast settling times, making the PLR350 ideal for fine position correction in assembly and optical applications where worm drives don't provide the necessary accuracy, throughput or life.

Versatile Application

The low profile of the PLR350 supports its use in tight spaces. The open throat design allows cables to be routed through its center up to tooling mounted above the stage. Multiple mounting hole patterns ease integration of the PLR350 into many applications.

Performance Verification

All PLR350 performance specifications are verified and a full set of accuracy & repeatability plots are included with each stage. Calibration data is also provided. In addition to test data, a 12 hour burn-in test is performed, insuring that the stage will perform as specified.

For more information and a complete datasheet, go to www.primatics.com

Performance Specifications w/ 5mm Ballscrew & 0.1 Micron Tape Encoder, Aluminum	PLR350
Travel (degrees)	+/- 5
Table Diameter (mm)	350
Mechanical Drive System	Class 5, 5mm Lead Ballscrew
Max Speed (degrees / sec)	40
Axial Runout (microns)	+/- 0.5
Radial Runout (microns)	+/- 1
Accuracy (arc-sec)	+/- 2
Bi-directional Repeatability (arc-sec)	+/- 1
Minimum Resolution (arc-sec)	0.12
Acceleration (deg-sec ²)	360
Axial Load Capacity (kg)	140
Radial Load Capacity (kg)	70
Weight (kg)	26.2



Linear Positioning

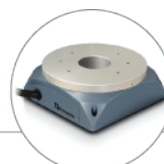

Rotary Positioning



Motion Controls

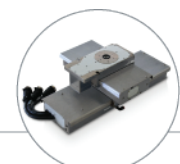

OEM Solutions

MODEL NUMBER CONFIGURATION

OPTIONS :

SAMPLE MODEL NUMBER :

PLR350 AL P E1 H1 L1 M1 P1

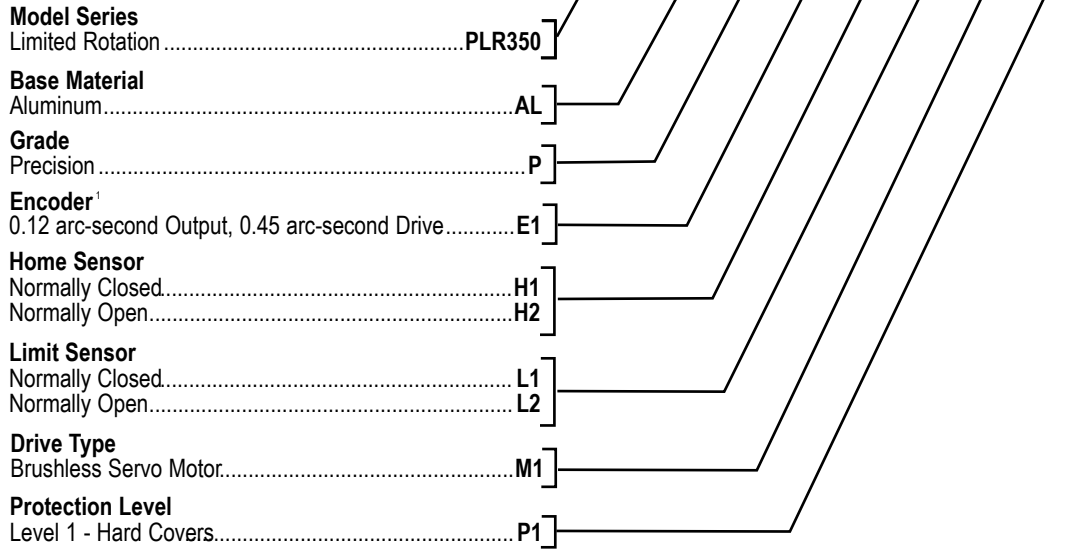

¹The output encoder directly reads the rotary position. The drive encoder is on the motor drive and is used for motor velocity feedback for dual-loop positioning control.