

Feature Summary

- Direct drive continuous rotary motion
- Compact design; at only 55 mm (PDR110), 60 mm (PDR160) & 75 mm tall (PDR210), the PDRs are among the most compact direct drive stages on the market.
- Low maintenance & long life; integrated brushless servo motor drivetrain eliminates gear wear, backlash and torque variation.
- Resolutions to 0.18 arc-seconds
- Clean design; all multiplication electronics are internal and there is only one cable necessary for external connections
- Oversized cross roller bearing and non-contact drivetrain guarantee long, trouble-free operation
- Error mapped accuracy option
- Class 10 cleanroom option

Overview

Primatics PDR Series rotary tables are among the most advanced direct drive tables available. They feature a high performance direct drive motor that creates arc second repeatability and fast settling times, making the PDR series ideal for semiconductor wafer inspection, high speed laser machining & precision metrology. The compact design also yields a smaller footprint than comparable worm drives.

Smart Design

The PDR series rotary stage incorporates a high power brushless servo motor drivetrain. Direct output metrology is provided by a high resolution optical encoder mounted directly to the rotating platen yielding resolutions down to 0.18 arc-seconds. Internal multiplication electronics and a single cable exit from the PDR simplifies integration & cable management. An oversized cross roller bearing supports the rotating platform, delivering high load capacity, excellent rigidity and long life. A large through hole allows convenient routing of vacuum and pneumatic air lines.

Superior Performance

The PDR's neodymium high efficiency servo motor permits greater acceleration, shorter settling times and less motor heating than other types of direct drive stages. In addition, the PDR motors have a high pole count, which aids in obtaining extremely low velocity ripple, even at very low speeds. The PDR's high performance motor, coupled with its platen mounted high resolution glass scale, results in high servo stiffness over a wide dynamic range.

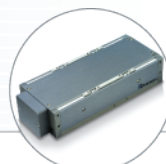

Linear Positioning

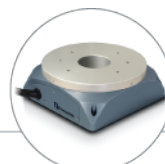

Rotary Positioning

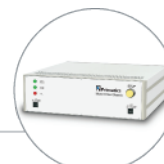

Motion Controls



OEM Solutions

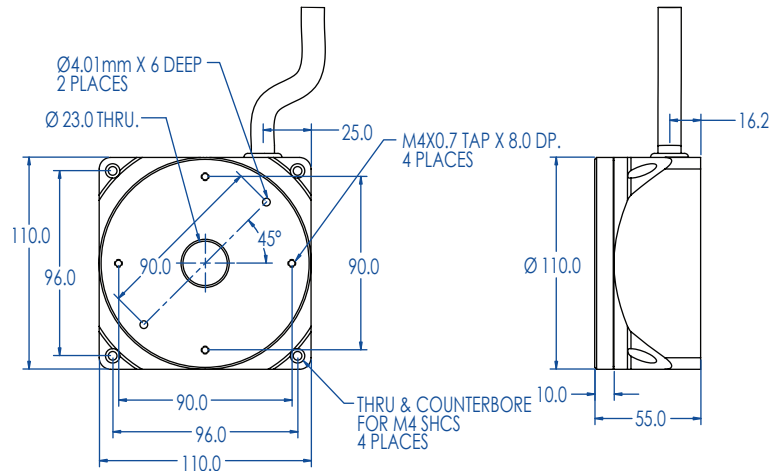

PDR160 DRAWINGS

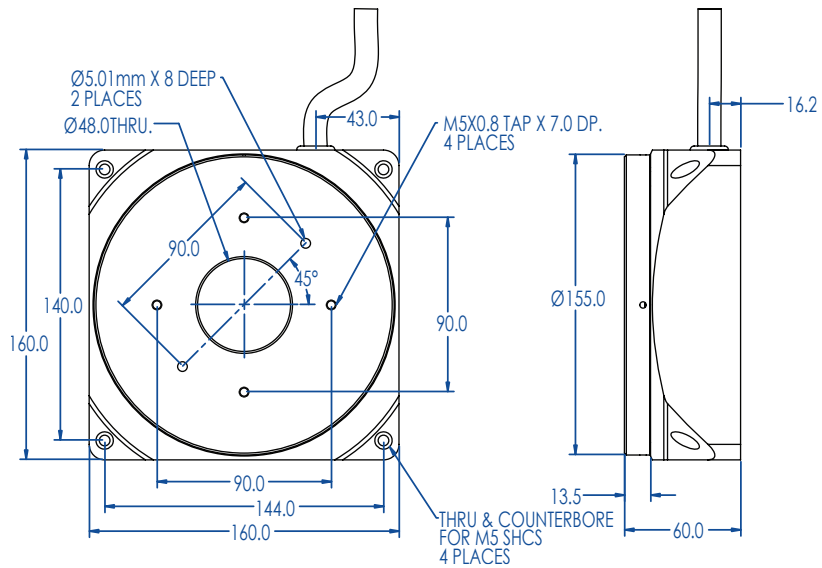

PDR210 DRAWINGS

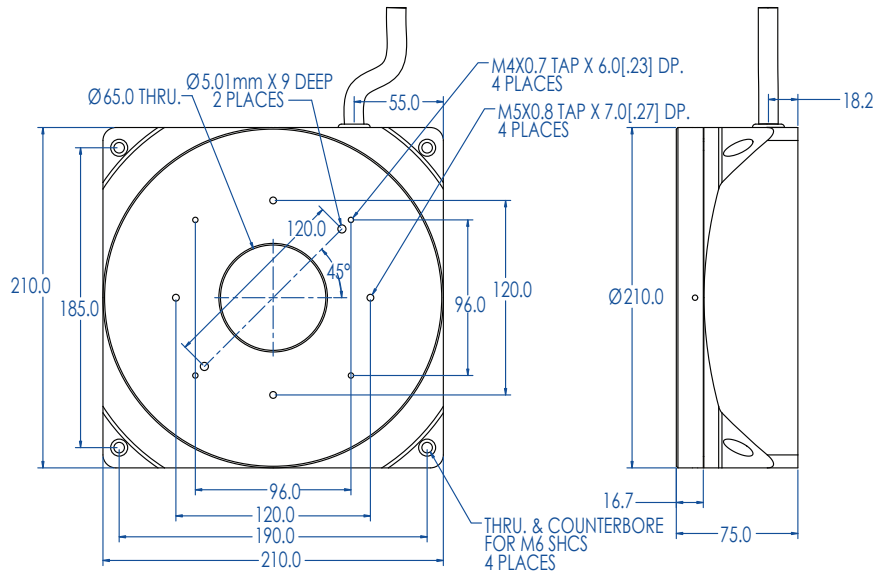

Direct Drive - Glass Encoder	PDR110			PDR160			PDR210		
Travel (degrees)	360								
Resolution (arc-seconds)	0.36	3.6	21.6	0.25	2.0	16	0.18	1.0	11.25
Accuracy (arc-seconds)	+/- 50		+/- 80	+/- 30		+/- 50	+/- 30		+/- 40
Error Mapped Accuracy w/ E3 Rotary Encoder (arc-seconds)	+/- 5								
Max Speed (rpm) ^{1,2}	110	350	75	350	55	300	350		
Bi-directional Repeatability (counts)	+/- 4	+/- 2	+/- 4	+/- 2	+/- 4	+/- 2			
Axial Runout (µm)	5			5			6		
Radial Runout (µm)	6			6			8		
Continuous Torque (N-m) ^{2,3}	0.4			0.9			4.1		
Peak Torque (N-m) ^{2,4}	2.7			7.2			30.2		
Axial Load Capacity (kg)	10			20			30		
Radial Load Capacity (kg)	5			10			15		
Weight (kg)	1.9			3.8			9.0		

¹ Resolution & Controller Dependant

² Assumes 100 VDC Bus

³ Assumes 25°C Temperature Rise

⁴ At 10% duty cycle and 1 second maximum

All specifications subject to change w/o notice.

TECHNICAL DATA

Rotary Motor Specification	PDR110	PDR160	PDR210
Continuous Torque (N-m) ¹	0.47	0.94	4.12
Continuous Current (Amps)	0.8	1.5	2.9
Peak Torque (N-m) ^{2,3}	2.7	7.2	30.2
Peak Current (Amps)	4.8	11.2	21.3
Torque Constant (N-m/amp)	0.58	0.64	1.42
Back EMF Constant (V/Krpm)	60.5	67.5	148.7
Resistance (Ω)	20.7	8.9	4.7
Inductance (mH)	20.0	18.2	14.7
Motor Constant (N-m-/Watt)	0.12	0.21	0.65
Thermal Resistance (C/W)	1.8	1.3	0.6
Motor Poles	12		

Stage Information	PDR110	PDR160	PDR210
Tabletop Inertia (kg-m ²)	6.52E-4	2.52E-3	1.27E-2
Maximum Acceleration (rps) ² (unloaded) ²	450	300	160
Max Breakaway Torque (N-m)	0.08	0.08	0.12
Max Running Torque (N-m)	0.07	0.07	0.10
Maximum Motor Bus Voltage (VDC)	100		
Length of Stage Cable (mm)	450		
Bearing Life x 10 ⁶ (Revs)	100		
Max Inertial Payload (kg-m ²)	0.01	0.1	1.0

¹ Assumes 25°C Temperature Rise

² Assumes 100 VDC Bus

³ At 10% duty cycle and 1 second maximum

All specifications subject to change w/o notice.

Encoder Specifications	Specification
Input Power (ma)	5 VDC +/- 5%, 330 ma
Output	Square wave differential line driver
Reference (Z channel)	Synchronized pulse, duration equal to one resolution bit

Home Specifications	Specification
Input Power	+12 to +24 VDC, 50 ma
Output	NC Current Sinking, Sink current maximum of 100 ma

Hall Effect Specifications	Specification
Input Power	+5 to +12 VDC, 30 ma
Output	Open collector, Current sinking, 20 ma Max

CONNECTOR PIN OUTS

Servo Axis connector for rotary tables that include motor and encoder

Mating Connector: FCI (Burrndy) Male, circular connector, 28 contacts, size 20 shell pin-out

Pin	Function
A	Motor A
B	Motor B
C	Motor C
D	Motor Shield
E	Encoder 5V - power for encoder
F	Encoder A+ output
G	Encoder A- output
H	Encoder B+ output
J	Encoder B- output
K	Encoder Shield
L	12VDC - for limit, home, and temp sensor
M	DCCOM
N	Home - switch to DCCOM when on forward side of home position
P	NC
R	NC

Pin	Function
S	Chassis
T	Hall V+
U	Hall V-
V	Encoder Common
W	Encoder Index +
X	Encoder Index -
Y	NC
Z	NC
a	NC
b	Hall A
c	Hall B
d	Temperature monitor - connect to DCCOM for temperature OK
e	Hall C

MODEL NUMBER CONFIGURATION

OPTIONS:

SAMPLE MODEL NUMBER:

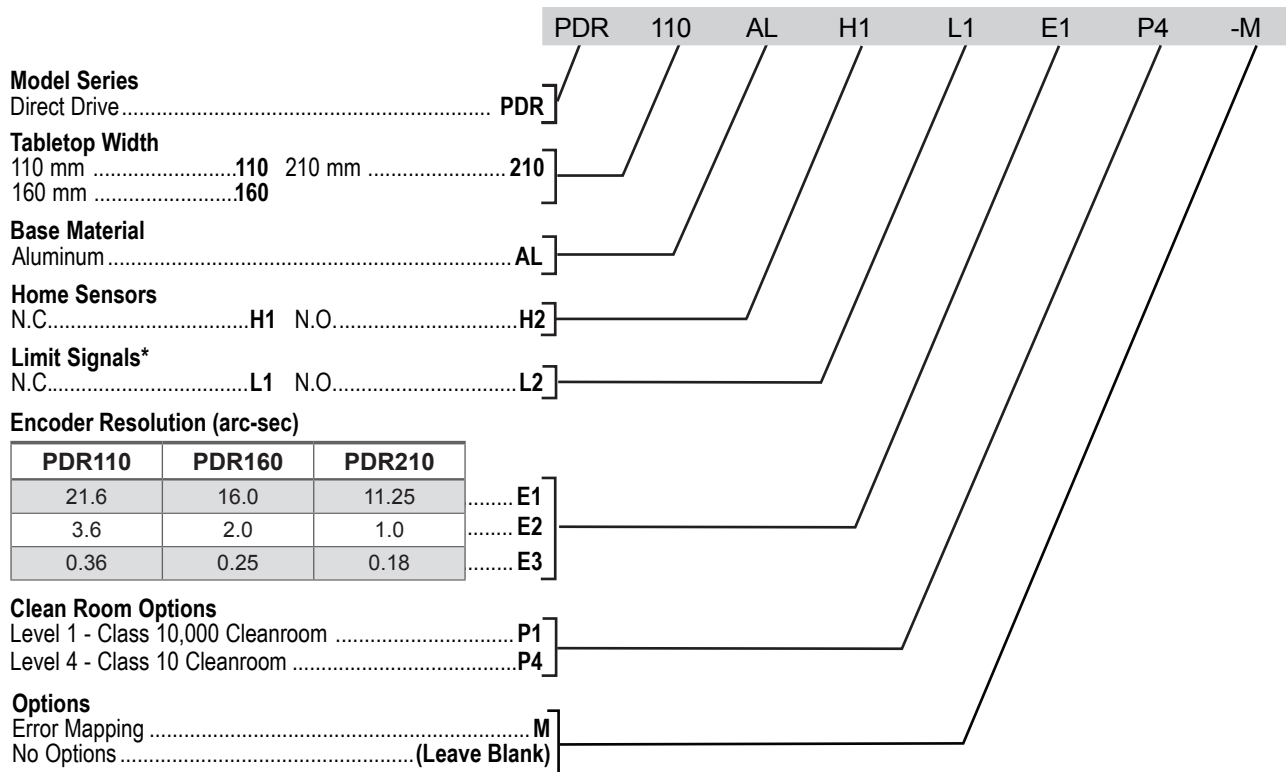

*The PDR does not include limit switches. The Limit Signal options are provided for compatibility with motion controller requirements.

