



Reference & Maintenance Manual

PLR110 Rotary Stage



Linear Positioning

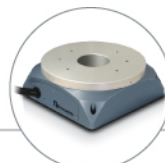

Rotary Positioning



Motion Controls



OEM Solutions



32114 Mallard Ave.
PO Box 409
Tangent, OR 97389-0409
U.S.A.

Phone: [541] 791-9678
Fax: [541] 791-9410
Toll Free: [888] 754-3111
Web: www.primatics.com
E-mail: info@primatics.com

Manual Revision Information

Publication Date	Notes
Mar 2011	Original Document
Nov 2011	Added motor parameter table
Mar 2012	Corrected Fwd/Rev limit graphic, updated specification table

Notice: The descriptions, drawings, and specifications contained herein are subject to change. Primatics is not responsible for errors or omissions herein or for incidental damages in connection with the furnishing or use of this information. This document shall not be reproduced, photocopied, or duplicated, in whole or in part, without prior written approval of Primatics Corporation.

©Copyright 2011 by Primatics, Inc; All Rights Reserved. Primatics, the Primatics logo, PrimaFlex, PrimaSeal & SimpleMatch are trademarks of Primatics, Inc.

- Manual Revision Information2**
- 1) Overview4**
- 2) Introduction – About the Limited Rotation Stage5**
- 3) Personal Safety6**
- 4) Stage & Manual Conventions7**
 - 4.1) Direction of Motion7
 - 4.2) About the Encoder8
 - 4.3) Units of Measure.....8
- 5) Installation Preparations8**
 - 5.1) Heat and Humidity.....9
 - 5.2) Electrical Noise.....9
- 6) Installing the Positioning Stage10**
 - 6.1) Tools you will need..... 10
 - 6.2) Unpacking 10
 - 6.3) Mounting surface preparation 10
 - 6.4) Electrical Connection..... 11
 - 6.4.1) Motor Electrical Parameters 12
 - 6.4.2) Hall Effect Commutation Sequence 12
 - 6.5) Home and Limit Switch Adjustment 14
 - 6.6) Encoder Index 16
 - 6.7) PTC Thermistor 16
 - 6.8) Recommended System Test..... 16
- 7) Preventive Maintenance17**
- 8) Troubleshooting & Service17**
 - 8.1) Troubleshooting Help 17
 - 8.2) Service 17

1) Overview

This user guide is designed to help you install and maintain your custom rotary positioning stage application. Follow these steps to ensure correct stage installation and maximum stage life:

- Step 1* Review this entire user manual. Become familiar with all installation procedures prior to integrating your system.
- Step 2* Review the safety summary to develop an understanding of standard safety practices when installing and operating automated equipment.
- Step 3* Familiarize yourself with the conventions summary.
- Step 4* Review installation procedures. For best results, follow these procedures carefully.
- Step 5* Once you successfully complete all the installation procedures, you will be ready to install and operate your stage.
- Step 6* Review preventive maintenance section for proper lubrication schedule.

2) Introduction – About the Limited Rotation Stage

The PLR110 stage is a limited travel, large aperture rotary stage. It incorporates a direct drive brushless servo motor and high resolution encoder in a lightweight package. A home switch and index pulse on the encoder are used for determining a repeatable home position. Forward and reverse limit switches are encountered at the respective ends of stage travel.

Travel	± 60°
Payload	3.6 lbs
Orientation	Horizontal
Accuracy	± 30 arc-sec
Repeatability	±2 arc-sec
Resolution	0.43 arc-sec nominal
Axial Runout	+/- 3 microns
Radial Runout	+/- 5 microns
Continuous Torque	0.5 N-m
Peak Torque	1.8 N-m
Axial Load Capacity	2 kg
Radial Load Capacity	0.8 kg
Rated speed	45 deg/sec
Motor type	Single stack frameless
Limit Sensors	2 Normally Closed sensors
Home Sensor	Yes, in center
Encoder type	0.2um steel tape scale
Cleanroom class	10,000
Finish	Black Anodize
Height	38 mm
Width	232 x 232 mm
Weight	3.8 kg

3) Personal Safety

Please review before installing your positioning stage

Observe common industrial safety practices when installing and operating automated equipment.

- Have power connections made by qualified personnel.
- Keep fingers and other items out of any opening in the stage while it is in operation since injury or damage may result.
- Provide a safe access route and adequate room for servicing.
- Perform the recommended periodic maintenance described in this document.
- Verify that the work envelope is free of obstructions before the positioning stage is powered.
- Insure that you have the feedback wired properly to the controller before applying power to the positioning stage. Improper feedback connections can cause a motor run-away condition that has the potential to damage the stage and injure an operator.
- Only trained operators of the positioning stage should be allowed near the work environment.
- If so equipped, identify emergency stop circuits and actuators in the workcell.
- Note the places in the workcell where pinch points occur, and provide adequate safety clearance or safety curtain.
- Never operate the motor in a location that could be splashed by water, exposed to corrosive or flammable gases or is near combustible substances since this may cause an electric shock, fire or malfunction.
- Never touch the motor, driver, or peripheral devices when the power is on or immediately after the power is turned off. The high temperature of these parts may cause burns.

4) Stage & Manual Conventions

4.1) Direction of Motion

The positive direction of motion is defined as a rotation in the counter clockwise direction as one is looking down on the stage platen. The encoder is wired so that the encoder count increases as the stage rotates in the positive direction. Figure 4-1 illustrates this convention.

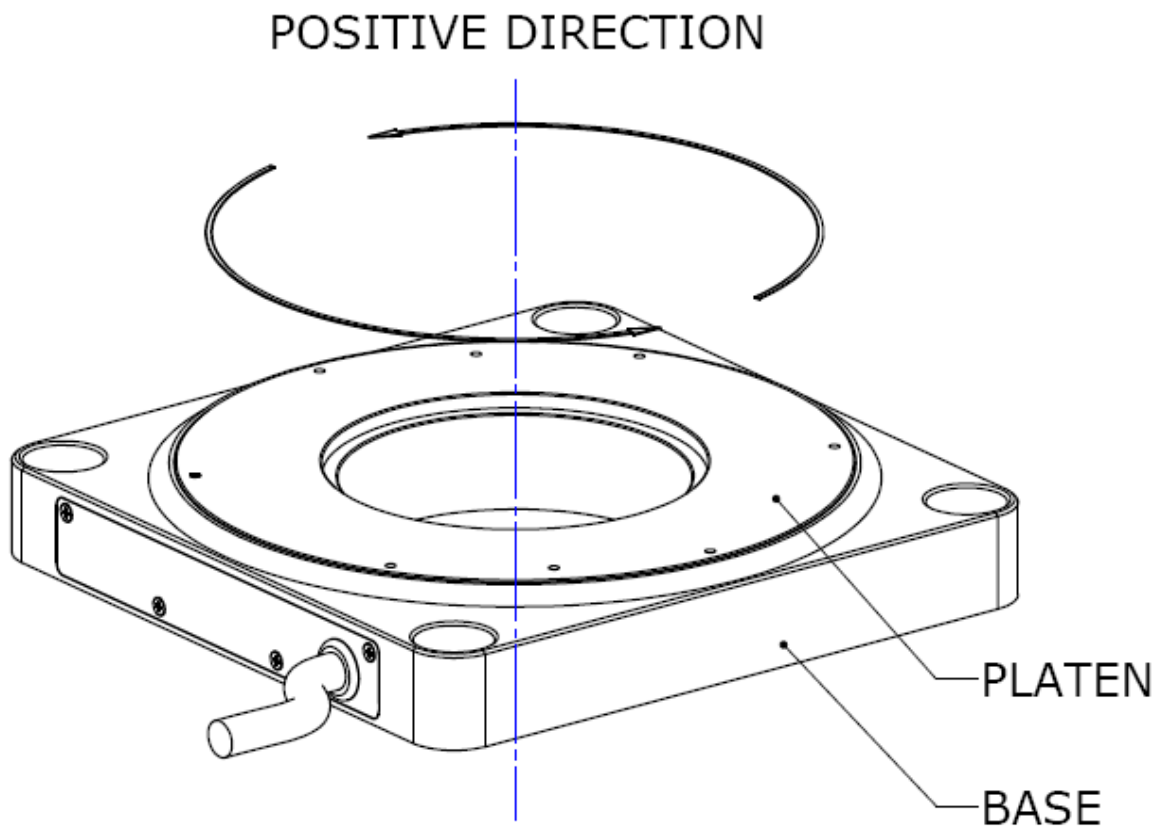

Figure 4-1. Positive direction convention

4.2) About the Encoder

The encoder ratio for each stage is determined through a calibration process. A "master encoder" is attached to the stage and the encoder ratio (counts/degree) for the stage is determined. This ratio is used when measuring the stage accuracy/repeatability. A sticker with this ratio is also attached to the stage near the serial number.

4.3) Units of Measure

Primatics uses the metric system for all specifications and dimensions. All linear dimensions are specified in millimeters. Angular displacement is specified in degrees. Accuracy error and repeatability for the rotary stage is expressed in arc-seconds (1 degree = 3600 arc-seconds). Load capacity is specified in kilograms and moment capacity is given in Newton-meters. All torque specifications are given in Newton-meters. Thrust specifications are given in Newtons.

The following table gives some common conversions into English units:

Metric Unit	English Unit
1 Kilogram equals	0.0685 slug*
1 micron equals	0.0000394 inch
1 millimeter equals	0.0394 inch
1 Newton-meter equals	8.85 in-lbs
1 Newton equals	0.2248 lbs
*1 Kg has a weight of 2.205 lb when $g = 9.8 \text{ m} / \text{s}^2$	

5) Installation Preparations

This section outlines installation environments. Unfavorable installation conditions may cause electric shock, fire, or breakdown. Certain breakdown situations or malfunctions in particular may lead to serious injury or other consequences. Assure that the unit is used under the following installation conditions:

- Indoors, free from being splashed by water
- No corrosive or inflammable gases present
- Well ventilated place, minimum level of dust or waste
- An environmental temperature range between 0-40°C, and humidity between 20-80% RH (location with no condensation) Note - These values show the range in which operation can be carried out safely, but not the environmental range in which stage accuracy can be guaranteed. Stage accuracy can be guaranteed at 20°C +/- 1°C
- Location should not be affected by electrical noise.
- Location should be where inspection and cleaning can be performed without difficulty.

5.1) Heat and Humidity

All positioning stages are assembled and tested at 20°C. Any stage calibrations are also performed at 20°C. For optimum accuracy the ambient temperature should be maintained at 20°C. Deviations from this nominal temperature may result in degraded accuracy performance.

5.2) Electrical Noise

Electrical noise is the corruption of signals carried over low voltage wires. Encoder signals can be corrupted resulting in spurious encoder counts thus causing the stage to drift. Grounding, shielding, and spatial separation are all countermeasures to reduce the influences of electrical noise on performance. You can minimize the potential for electrical noise by observing the following installation precautions:

- Physically separate low voltage conductors from those carrying high voltage.
- Ensure that all components are properly grounded.
- Ensure that all wiring is properly shielded.

6) Installing the Positioning Stage

6.1) Tools you will need

The rotary stage uses the following fasteners:

Rotating Platen M4

From the factory, the stage is delivered with a M4 x 4 set screw installed in one of the platen mounting holes. This set screw is used to plug a through hole but can be removed if needed to mount the payload. If the hole is to be unused, the set screw should be installed to prevent debris from fouling the hole.

6.2) Unpacking

Carefully remove the stage from its shipping crate and inspect it for evidence of shipping damage. Report any damage immediately to your authorized dealer.

Improper handling of the stage may degrade its performance. Follow these guidelines when handling and mounting your stage.

- 1) Do not drop the stage onto its mounting surface. Place the stage gently on the mounting surface. Impact loads can cause high spots on mounting surfaces, misalignment of drive components and warping of the base.
- 2) Do not drill holes into the stage. If additional holes are necessary, contact your local distributor.
- 3) Lift the stage by its base structure only.
- 4) Stage disassembly and alteration, unless specified otherwise, may void warranty.

6.3) Mounting surface preparation

The characteristics of the surface the positioning stage is mounted to will have a large effect on system performance. An accurate and flat positioning stage will conform to the shape of its mounting surface, therefore a flat mounting surface is required. For best results in maintaining stage specifications we suggest the following:

- 1) Use a laboratory Grade AA granite surface plate
- 2) Before mounting stage, inspect for burrs or dings on the stage mounting surfaces
- 3) Clean all mounting surfaces with acetone

In the absence of a granite surface plate, we recommend a base plate made of the same material as the base of the stage. A mounting surface constructed out of a material different from the stage base material can introduce warping in the stage in the presence of a thermal gradient. The surface flatness should match the requirements of the application; a good starting point is to have the mounting surface flat to less than 5-8 μ m.

6.4) Electrical Connection

Electrical connections to the stage are through single 28 pin connector as shown in Table 6-1.

Table 6-1: Electrical Connector, 28 pin panel mount

Pin	Function
A	Motor A
B	Motor B
C	Motor C
D	Motor Shield
E	Encoder 5V – power for encoder
F	Encoder A+ output
G	Encoder A- output
H	Encoder B+ output
J	Encoder B- output
K	Encoder Shield
L	12 - 24VDC - for limit & home
M	DCCOM
N	Home
P	Brake release output (24VDC) for optional brake
R	Brake return for optional brake
S	Stage Base
T	Hall V+
U	Hall V-
V	Encoder 0V
W	Encoder Index +
X	Encoder Index -
Y	Forward Limit Switch
Z	Reverse Limit Switch
a	Signal Shield
b	Hall A
c	Hall B
d	Temperature monitor – connect to DC Common for temperature OK
e	Hall C

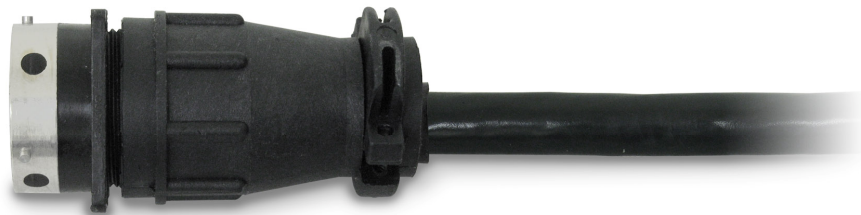

6.4.1) Motor Electrical Parameters

Rotary Motor Specification		
Continuous Torque (N-m)	0.5	@ 15deg C temp rise
Continuous Current (Amps _{rms})	1.52	@ 15deg C temp rise
Peak Torque (N-m)	1.8	@ 10% duty cycle, 1sec max on time
Peak Current (Amps _{rms})	5.45	@ 10% duty cycle, 1sec max on time
Torque Constant (N-m/Amp _{rms})	0.33	
Back EMF (V/Krpm)	28.5	
Resistance (ohms)	3.7	
Inductance (mH)	3.5	
Stage Platen Inertia (kg-m ²)	0.0066	
Motor Constant (N-m/√Watt)	0.14	
Thermal Resistance (°C/W)	1.2 (stage)	
Motor Poles	36	

6.4.2) Hall Effect Commutation Sequence

The following diagram shows the motor signal timing for the Servo Motor option

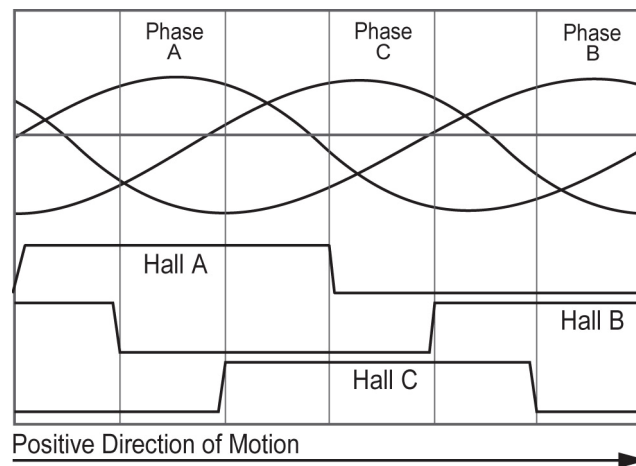

Figure 6-1: Motor commutation chart

The following diagram shows the encoder signal timing for the Encoder option

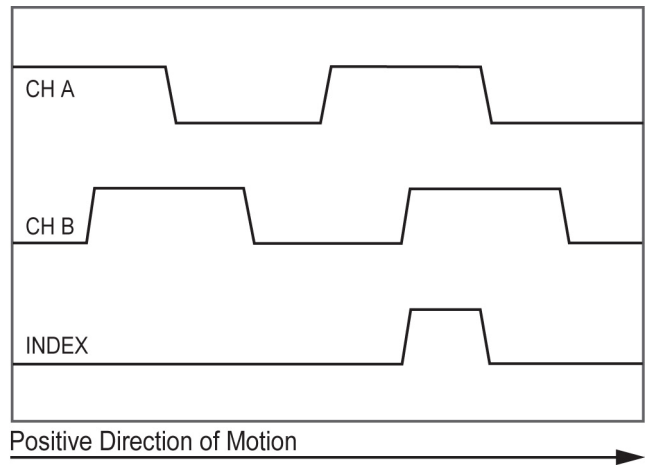

Figure 6-2: Timing diagram for the encoder signals

6.5) Home and Limit Switch Adjustment

The home switch uses a reflective sensor located in the base of the stage. A white reflective strip sweeps 120° of the circumference of the stage and is viewed with this reflective sensor. One half of this strip is covered with a black mask. When the sensor is over the white area, the output signal conducts current and closes the home switch. When the sensor is over the black, the switch is open. The home switch is fixed at the factory and cannot be adjusted. End of travel optical limit switches trigger when the platen is rotated past its nominal travel of ±60° from center. A reference index on the encoder is located at the nominal center of travel. The limit switches and encoder index are fixed at the factory and cannot be adjusted. See Figures 6-4, 6-5, & 6-6 for clarification.

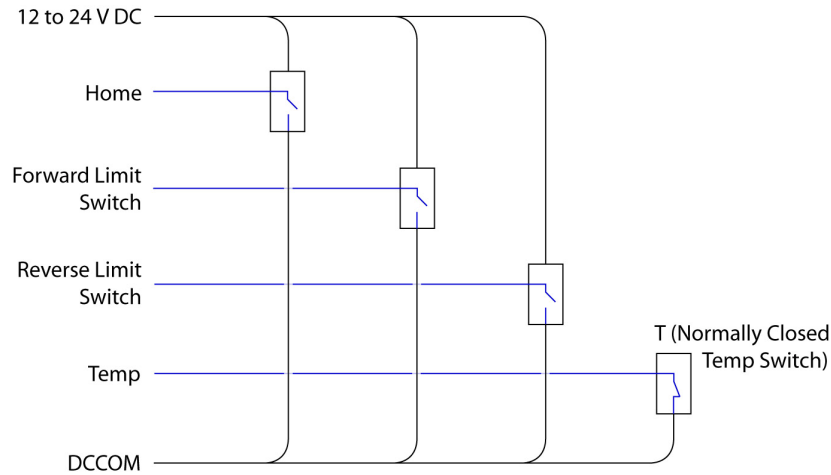

Figure 6-3: Equivalent Home, Limit and Temp Circuit Schematic

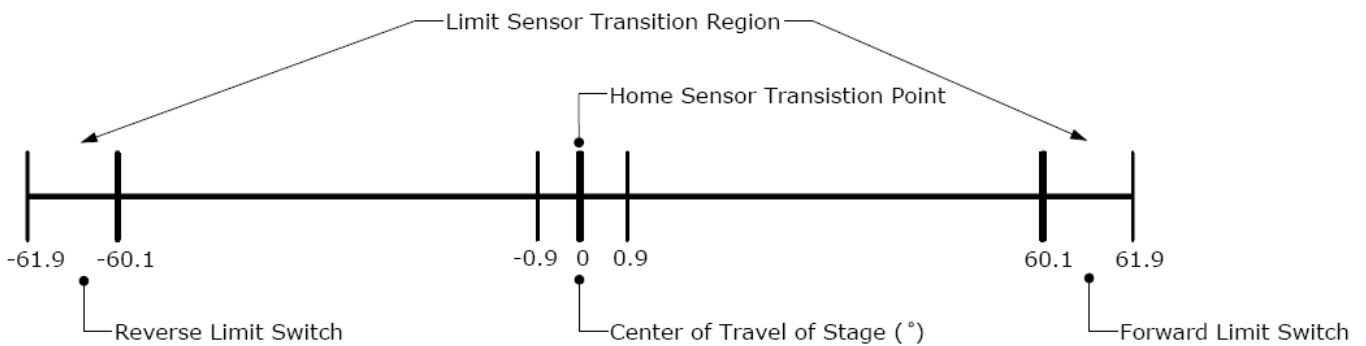

Figure 6-4: Limit and Home Sensor Transition Ranges

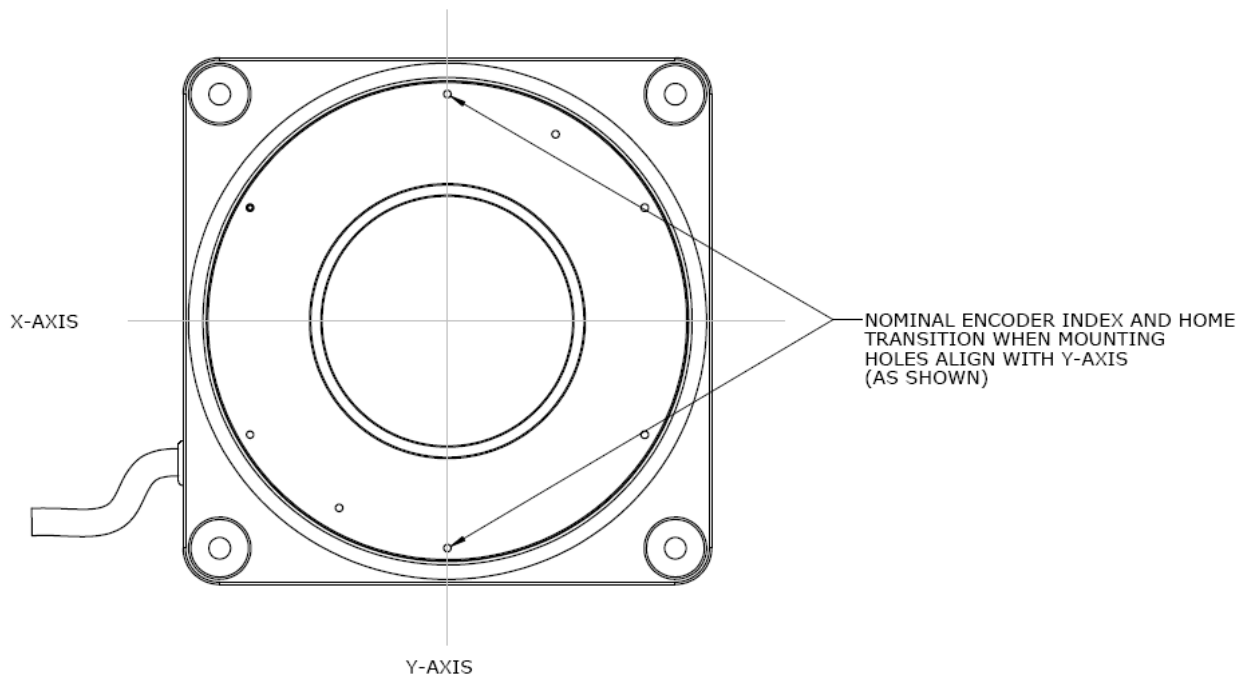

Figure 6-5: Encoder Index and Home Transitions

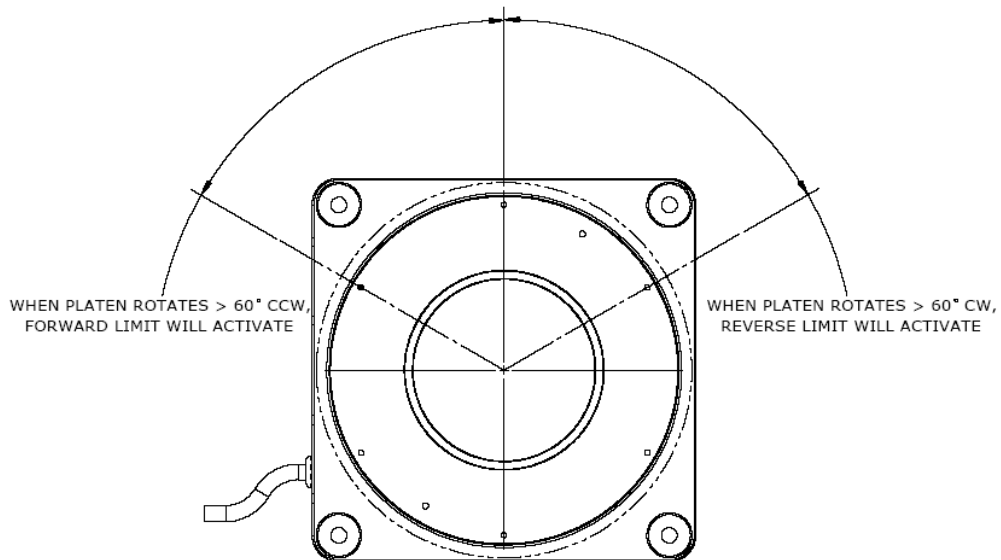

Figure 6-6: Limit Transitions

6.6) Encoder Index

The linear encoder reference signal (index) is located at the nominal center of travel and is output in both directions but repeatability is guaranteed only in one phased direction. The reference mark output is synchronized with the incremental channels, giving it a unit of resolution pulse width. The encoder index is phased in the negative direction. Therefore, during a homing routine, the stage should travel to the home vane transition, move to 2° positive, and then start searching for the index in the negative direction. It is recommended that the homing procedure be performed as part of any power-up sequence to ensure the correct datum position is recorded.

6.7) PTC Thermistor

The motor is equipped with a PTC thermistor configured to respond when the motor temperature surpasses 100°C. The pin-out of the connector is detailed in Table 6-1.

6.8) Recommended System Test

Before attaching a load or applying power to your stage, verify the encoder and limit switches are working properly. Move the stage platen by hand in the positive direction and verify the encoder count is increasing (see Figure 4-1). Runaway conditions caused by miswired encoders can result in stage damage and personal injury. Move platen to each end of travel to ensure limit switches are working properly. When closing the position loop for the first time, set the torque limit of your controller to a low value and use conservative tuning gains. Once the control loop is working properly, payloads can be added to the stage platen.

7) Preventive Maintenance

The rotary stage does not require periodic maintenance. The motor and encoder are non-contact devices and the bearing element is pre-packed with grease and does not need relubricating.

The stage should be kept clean and a soft cloth should be used wipe down the stage. Do not use compressed air to spray away dust since this may force dust into crevices.

8) Troubleshooting & Service

8.1) Troubleshooting Help

For further assistance contact the factory:
M-F 8AM to 5PM Pacific Time

Phone:	[541] 791-9678
Fax:	[541] 791-9410
Toll Free:	[888] 754-3111
Web:	www.primatics.com
E-mail:	service@primatics.com

8.2) Service

Should your device require factory service, contact the factory for a Return Materials Authorization (RMA). When inquiring about an RMA please have the following information available:

- Your contact information (name, phone, email, address)
- Unit Serial Number
- Symptom of problem
- History of troubleshooting steps already taken



Figure 8-1: Unit Serial Number & Encoder Ratio Sticker Location