

Reference & Maintenance Manual

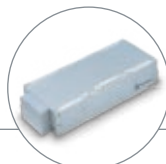

Linear Positioning

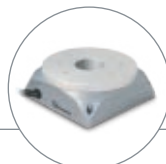

Rotary Positioning



Motion Controls

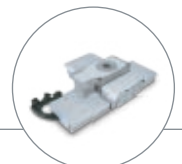

Engineered Solutions



**32114 Mallard Ave.
PO Box 409
Tangent, OR 97389-0409
U.S.A.**

Phone: [541] 791-9678
Fax: [541] 791-9410
Toll Free: [888] 754-3111
Web: www.primatics.com
E-mail: info@primatics.com

PZA25 Manual Revision Information

Publication Date	Notes
Oct 2003	
March 2003	Changed recommended grease from Lithium #2 to NSK Clean room grease
April 2005	Updated look & formatting
November 2006	Added pitch, roll & yaw graphic
January 2007	Updated Ordering Info
June 2007	Updated Table 7-1
Aug 2010	Removed references to linear encoder

Notice: The descriptions, drawings, and specifications contained herein are subject to change. Primatics is not responsible for errors or omissions herein or for incidental damages in connection with the furnishing or use of this information. This document shall not be reproduced, photocopied, or duplicated, in whole or in part, without prior written approval of Primatics Corporation.

For Specifications, Dimensioned Drawings and additional information, refer to the PZA25 Datasheet available from our website at www.primatics.com.

©Copyright 2007-2010 by Primatics, Inc; All Rights Reserved. Primatics, the Primatics logo, PrimaFlex, PrimaSeal & SimpleMatch are trademarks of Primatics, Inc.

PZA25 Manual Revision Information	2
1) Overview	4
2) Introduction – About the PZA25	5
3) Model Configuration	6
⚠ 4) Personal Safety ⚠	7
5) Conventions	8
5.1) Direction of Motion	8
5.2) Units of Measure	9
6) Installation Preparations	10
6.1) Heat and Humidity	10
6.2) Contamination	10
6.3) Electrical Noise	11
7) Installation Procedures	12
7.1) Tools you will need	12
7.2) Unpacking	12
7.3) Mounting surface preparation	13
7.4) Mounting the PZA25	13
7.5) Electrical Connections	14
7.5.1) Color Codes for Pigtailed Cable	16
7.5.2) Hall Effect Commutation Sequence	17
7.6) Home & Limit Switches	18
7.6.1) Home Sensor	18
7.7) Limit Switch Adjustment	18
7.8) Recommended System Test	19
8) Preventive Maintenance	20
8.1) Lubrication	20
9) Troubleshooting & Service	21
9.1) Troubleshooting Help	21
9.2) Service	21

1) Overview

This user guide is designed to help you install and maintain your PZA25 Series vertical positioning stage application. Follow these steps to ensure correct stage installation and maximum stage life:

- Step 1* Review this entire user manual. Become familiar with all installation procedures prior to integrating your system.
- Step 2* Review the safety summary to develop an understanding of standard safety practices when installing and operating automated equipment.
- Step 3* Familiarize yourself with the conventions summary.
- Step 4* Review installation procedures. For best results, follow these procedures carefully.
- Step 5* Once you successfully complete all the installation procedures, you will be ready to install and operate your stage.
- Step 6* Review preventive maintenance section for proper lubrication schedule.

2) Introduction – About the PZA25

The PZA Series is a general purpose ballscrew-driven elevator stage with an integrated brushless servo motor. It utilizes a moving wedge design that converts horizontal movement from a ballscrew to vertical elevation. The design and components ensure sub-micron resolution in a compact profile and make the PZA ideal for semiconductor inspection, fiber optics assembly and machine vision applications requiring smooth motion, exceptional stiffness, and high resolution.

Many customers choose the Primatics Motion Drive Chassis (MDC) to power PZA25 stages. The MDC is a modular system that packages motor drivers, encoder interfaces, power supplies and safety systems into a single chassis. It acts as an intermediary between a Galil Optima, National Instruments 7344 or Delta Tau PMAC II motion control cards and a Primatics positioning stage. Pre-wired high-flex cables are available to allow a convenient connection from the stage to the MDC chassis. The MDC drive chassis interfaces 3rd party controllers via a removable interconnect module. These interconnect modules conform to each manufacturer's interconnect cable, and internally route all the command and I/O signals.

Optionally, a Primatics positioning stage can be used with many third party controller and amplifier systems. In this case, a pigtailed cable is available to simplify the connection between the PZA25 stage and controls.

3) Model Configuration

MODEL NUMBER CONFIGURATION

OPTIONS:

SAMPLE MODEL NUMBER:

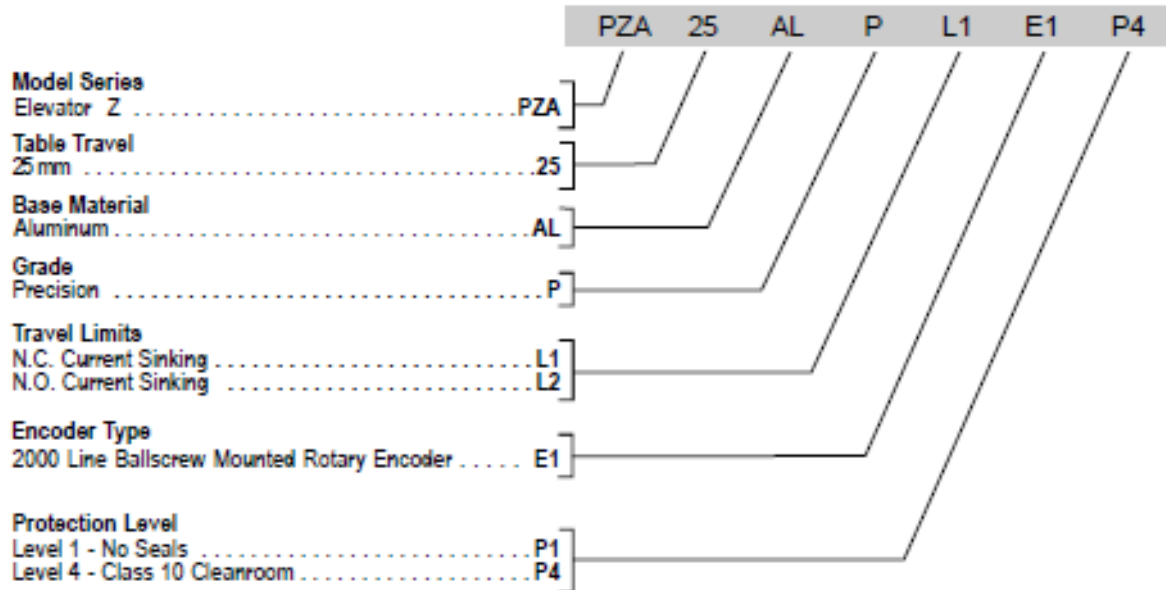

4) Personal Safety

Please review before installing your positioning stage

Observe common industrial safety practices when installing and operating automated equipment.

- Have power connections made by qualified personnel.
- Keep fingers and other items out of any opening in the stage while it is in operation since injury or damage may result.
- Provide a safe access route and adequate room for servicing.
- Perform the recommended periodic maintenance described in this document.
- Verify that the work envelope is free of obstructions before the positioning stage is powered.
- Insure that you have the feedback wired properly to the controller before applying power to the positioning stage. Improper feedback connections can cause a motor run-away condition that has the potential to damage the stage and injure an operator.
- Only trained operators of the positioning stage should be allowed near the work environment.
- If so equipped, identify emergency stop circuits and actuators in the workcell.
- Note the places in the workcell where pinch points occur, and provide adequate safety clearance or safety curtain.
- Never operate the motor in a location that could be splashed by water, exposed to corrosive or flammable gases or is near combustible substances since this may cause an electric shock, fire or malfunction.
- Never touch the motor, driver, or peripheral devices when the power is on or immediately after the power is turned off. The high temperature of these parts may cause burns.

5) Conventions

5.1) Direction of Motion

The positive direction of motion is defined as when the carriage elevates upward (overall height of stage increases). The encoder count increases as the stage travels in the positive direction. Figure 5-1 illustrates this convention.

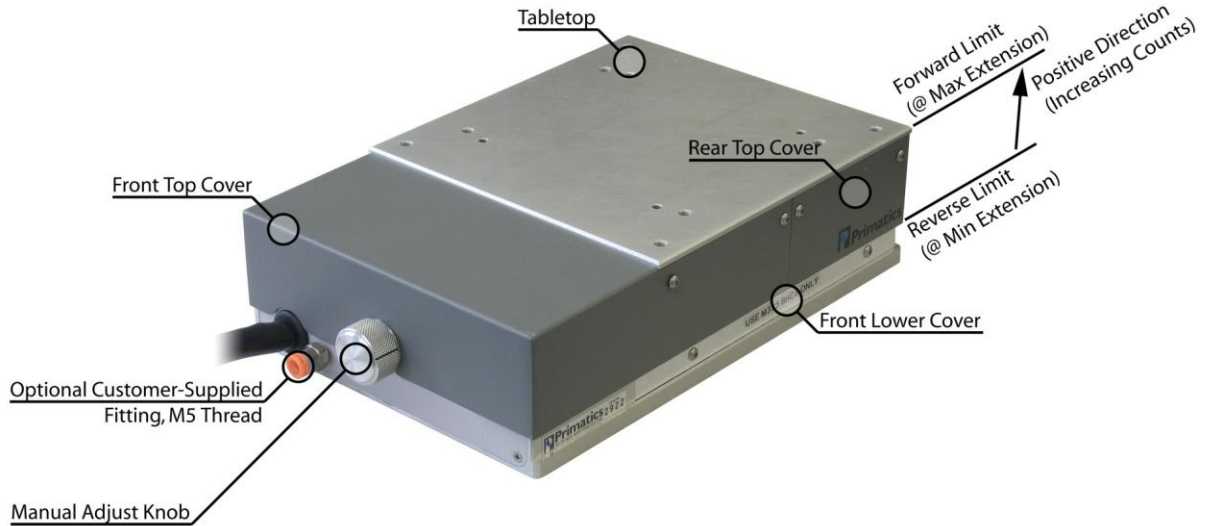

Figure 5-1: PZA25 Conventions

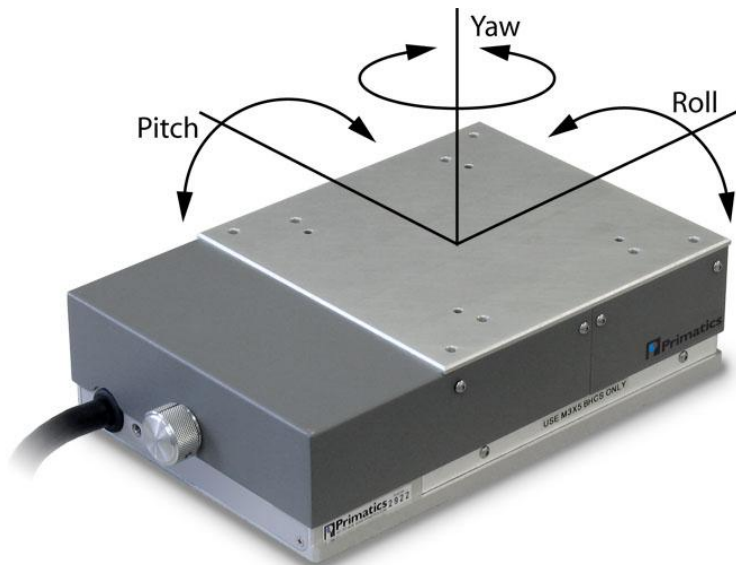

Figure 5-2: PZA25 Pitch, Roll & Yaw

5.2) Units of Measure

Primatics uses the metric system for all specifications and dimensions. All linear dimensions are specified in millimeters. Accuracy, repeatability, resolution, flatness and straightness for the PZA is specified in microns. Load capacity is specified in kilograms and moment capacity is given in Newton-meters. All torque specifications are given in Newton-meters. Thrust specifications are given in Newtons.

The following table gives some common conversions into English units:

Metric Unit	English Unit
1 Kilogram equals	0.0685 slug*
1 micron equals	0.0000394 inch
1 millimeter equals	0.0394 inch
1 Newton-meter equals	8.85 in-lbs
1 Newton equals	0.2248 lbs
*1 Kg has a weight of 2.205 lb when $g = 9.8 \text{ m} / \text{s}^2$	

6) Installation Preparations

This section outlines installation environments. Unfavorable installation conditions may cause electric shock, fire, or breakdown. Certain breakdown situations or malfunctions in particular may lead to serious injury or other consequences. Assure that the unit is used under the following installation conditions:

- Indoors, free from being splashed by water
- No corrosive or inflammable gases present
- Well ventilated place, minimum level of dust or waste
- An environmental temperature range between 0-40°C, and humidity between 20-80% RH (location with no condensation) Note - These values show the range in which operation can be carried out safely, but not the environmental range in which stages accuracy can be guaranteed. Stage accuracy can be guaranteed at 20°C +/- 1°C.
- Location should not be affected by electrical noise.
- Location should be where inspection and cleaning can be performed without difficulty.

6.1) Heat and Humidity

All positioning stages are assembled and tested at 20°C. Any stage calibrations are also performed at 20°C. For optimum accuracy the ambient temperature should be maintained at 20°C. Deviations from this nominal temperature may result in degraded accuracy performance.

Ballscrew driven stages are also susceptible to thermal expansion effects. The ballscrew nut can create a localized thermal gradient if driven at high speeds. Airflow through the stage can help minimize ballnut heating.

6.2) Contamination

Applications in dirty or dusty environments require the electrical, optical and mechanical components to be protected. The PZA25 series is intended for clean environments free from small particulates and fluids. The air the PZA25 is operated in should be clean and dry. The cover protection and high-pressure (60-120psi)/low flow air purge system is sufficient for environments generating moderate quantities of 0.5 mm and larger particles. However, for dusty, wet, or harsh environments or applications with continuous exposure to smaller contaminants, additional protection must be designed.

Airflow through a stage must be filtered and dry. The filtration system should reject particles larger than 2 microns. Air pressures between 60-100 psi are sufficient for convection cooling. A typical air source can be made suitable with the addition of an inline desiccant dryer and filter/regulator assembly. Humidity should be less than 85% and there should be no condensation in the environment in which the stage is used.

6.3) Electrical Noise

Electrical noise is the corruption of signals carried over low voltage wires. Encoder signals can be corrupted resulting in spurious encoder counts thus causing the stage to drift. Grounding, shielding, and spatial separation are all countermeasures to reduce the influences of electrical noise on performance. You can minimize the potential for electrical noise by observing the following installation precautions:

- Physically separate low voltage conductors from those carrying high voltage.
- Ensure that all components are properly grounded.
- Ensure that all wiring is properly shielded.

7) Installation Procedures

7.1) Tools you will need

The PZA25 positioning stage has mounting holes for M5 SHCS in the base and M4 and M5 tapped holes in the tabletop. M3 BHCS's are used to attach the hard covers. The lower rear cover must be secured with **M3 x 5mm** long fasteners. Longer fasteners will result in damage to the stage. A 2mm hex tool will remove all the hard cover screws. 3mm and 4mm hex tools are required for the stage mounting hardware.

7.2) Unpacking

Carefully remove the stage from its shipping crate and inspect it for evidence of shipping damage. Report any damage immediately to your authorized dealer.

Improper handling of the stage may degrade its performance. Follow these guidelines when handling and mounting your stage.

- 1) Do not drop the stage onto its mounting surface. Place the stage gently on the mounting surface. Impact loads can cause high spots on mounting surfaces, misalignment of drive components and warping of the base.
- 2) Do not drill holes into the stage. If additional holes are necessary, contact your local distributor.
- 3) Lift the stage by its base structure only. Do not lift by the motor drive assembly.
- 4) Stage disassembly and alteration, unless specified otherwise, may void warranty.

7.3) Mounting surface preparation

The characteristics of the surface the positioning stage is mounted to will have a large effect on system performance. An accurate and flat positioning stage will conform to the shape of its mounting surface, therefore a flat mounting surface is required. For best results in maintaining stage specifications we suggest the following:

- 1) Use a laboratory Grade AA granite surface plate
- 2) Before mounting stage, inspect for burrs or dings on the stage mounting surfaces
- 3) Clean all mounting surfaces with acetone

In the absence of a granite surface plate, we recommend a base plate made of the same material as the base of the stage. A mounting surface constructed out of a material different from the stage base material can introduce warping in the stage in the presence of a thermal gradient. The surface flatness should match the requirements of the application; a good starting point is to have the mounting surface flat to less than 5-8 μ m.

7.4) Mounting the PZA25

The following text and illustrations give instructions to accessing the PZA25 Mounting Holes.

- 1) Remove the fasteners in Rear Top Cover (area in red) with M2 Hex Wrench and slide forward.

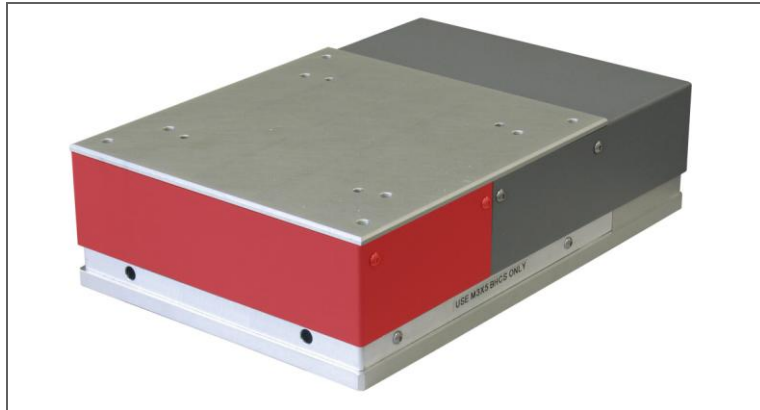

- 2) Remove the fasteners in Rear Lower Cover (area in red) with M2 Hex Wrench and slide forward.

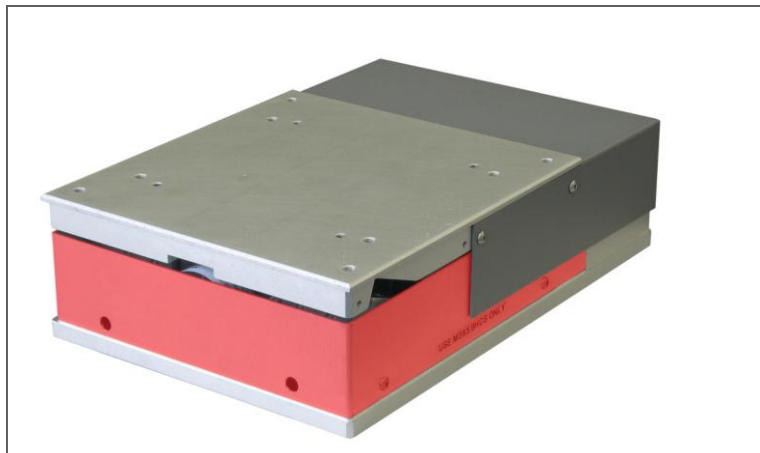

4) Mounting Holes are circled in white and outlined in red. Use the Manual Adjust Knob to raise the tabletop for access to these holes.

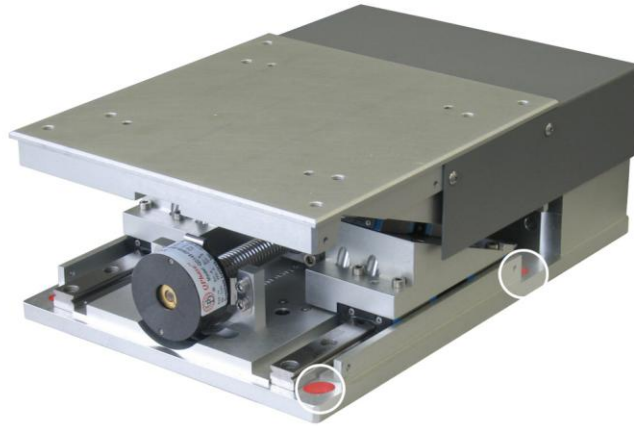

5) Replace both Rear Top and Rear Lower covers.

7.5) Electrical Connections

Electrical connections to the stages depend on the type of stage in use. All PZA25 models are terminated with a 450mm flexible cable with a 28 position circular connector on the end. The pin-out of this connector is shown with Table 7-1. This particular configuration is optimized for use with Primatics MDC drive chassis via an extension cable. Connections to other drives and controls are also made through this connector.

A popular option for applications not using the Primatics MDC drive chassis is the pigtailed extension cable. This is similar to the extension cable used to connect a stage to the MDC drive chassis, except the end that connects to the motor drive and controller is un-terminated. Section 7.6.1 shows the conductor assignments for this cable (when ordered with a ballscrew drivetrain and without an encoder).

Table 7-1: Mating Connector: FCI (Burndy) Male, circular connector, 28 contacts, size 20 shell

Pin	Function
A	Motor A
B	Motor B
C	Motor C
D	Motor Shield
E	Encoder 5V – power for encoder
F	Encoder A+ output
G	Encoder A- output
H	Encoder B+ output
J	Encoder B- output
K	Encoder Shield
L	12-24VDC - for limit, home, and temp sensor
M	DCCOM
N	Not used
P	Not used
R	Not used
S	Sensors Shield
T	Hall V+
U	Hall V-
V	Encoder Common
W	Encoder Index +
X	Encoder Index -
Y	Forward Limit Switch
Z	Reverse Limit Switch
a	N.C.
b	Hall A
c	Hall B
d	Temperature monitor
e	Hall C



7.5.1) Color Codes for Pigtailed Cable

Cable consists of 3 independent shielded “pods”: One for motor signals, one for encoder signals & a 3rd for sensors. Each of the pods is described below.

Cable 1

	Color	Function
█	Black	Motor A
█	Red	Motor B
□	White	Motor C
█	Shld	Motor Shield

Cable 2

	Color	Function
█	Red	Encoder 5V
□	White	Encoder A+ output
█	Yellow	Encoder A- output
█	Green	Encoder B+ output
█	Blue	Encoder B- output
█	Shld	Encoder Shield
█	Black	Encoder Common
█	Orange	Encoder Index +
█	Brown	Encoder Index -



Cable 3

	Color	Function
█	Green	12VDC
█	Blue	DCCOM
□	White	Home
□ / █	Wht/Red	Not used
□ / █	Wht/Black	Not used
█	Shld	Chassis
█	Black	Hall V+
█	Brown	Hall V-
█	Violet	Forward Limit Switch (Grounded)
█	Gray	Reverse Limit Switch (Grounded)
█	Red	Hall A
█	Orange	Hall B
█	Tan	Temperature Monitor
█	Yellow	Hall C

Table 7-2: Pigtail conductor assignments

7.5.2) Hall Effect Commutation Sequence

The following diagram shows the motor signal timing for the Servo Motor option

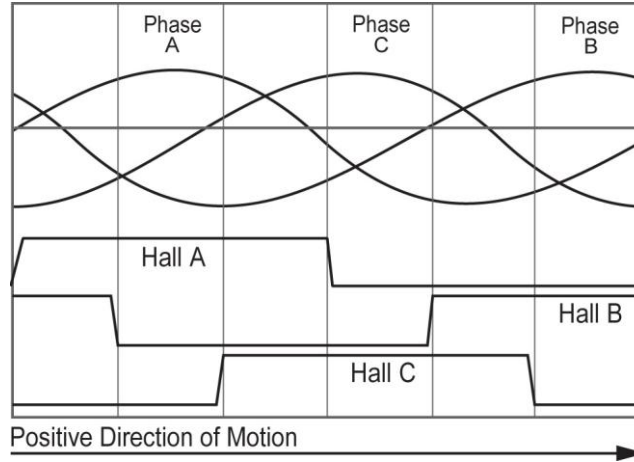

Figure 7-2: Motor commutation chart

The following diagram shows the encoder signal timing for the Encoder option

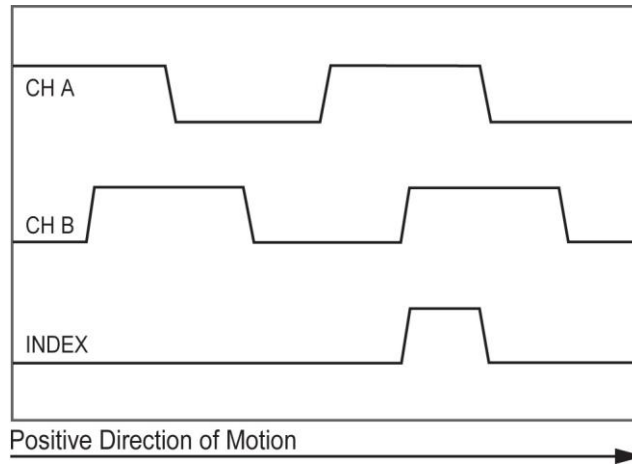

Figure 7-3: Timing diagram for the encoder signals

7.6) Home & Limit Switches

7.6.1) Home Sensor

A home sensor is not present because the PZA25 was designed with the idea of finding a home position near the reverse limit of travel. This facilitates moving downward (normally out of harms way) in the homing process. There is an encoder index transition every 0.8 mm of vertical travel. So, the anticipated homing procedure would be to search for the reverse limit sensor transition and then move up to the first encoder index transition in order to establish a repeatable home position.

7.6.2) Limit Options:

The Limit switches are ordered in either the Normally Closed (L1) or Normally Open (L2) configuration

L1: When the carriage is in the normal operating range of travel, both limit switches are closed. When the carriage encounters a limit the switch opens. The switch will close again when the carriage is moved away from the switch.

L2: When the carriage is in the normal operating range of travel, both limit switches are open. When the carriage encounters a limit the switch closes. The switch will open again when the carriage is moved away from the switch.

7.7) Limit Switch Adjustment

The limit switch positions have been preset at the factory and cannot be adjusted. Figure 7-1 shows the relative placement of the limit transitions. Both limit switches can be ordered normally open or normally closed.

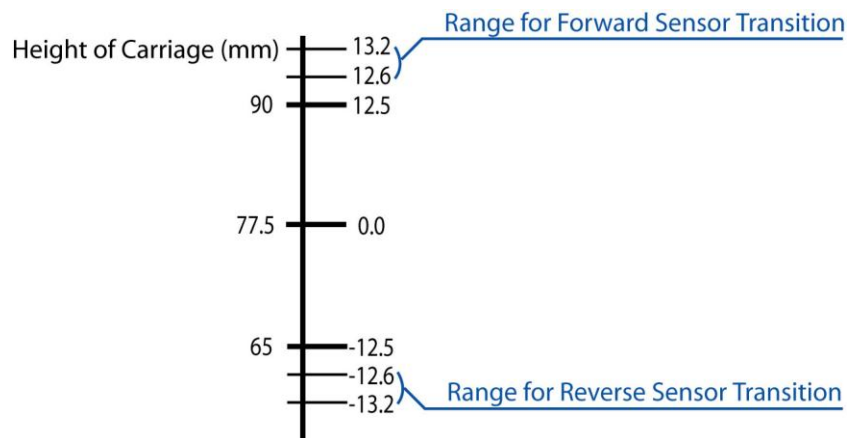

Figure 7-1: PZA25 Limit Sensors

7.8) Recommended System Test

Before attaching a load or applying power to your stage, verify the encoder and limit switches are working properly. Move the stage carriage by hand using the manual adjust knob at the end of the stage. Runaway conditions caused by miswired encoders can result in stage damage and personal injury. When closing the position loop for the first time, set the torque limit of your controller to a low value and use conservative tuning gains. Once the control loop is working properly, payloads can be added to the stage carriage.

8) Preventive Maintenance

Performing preventive maintenance procedures on your stage will extend its life and improve its long-term performance.

8.1) Lubrication

Use clean room grease to lubricate the ballscrew and linear guide components. We recommend NSK grease part #GRS LG2. For low duty cycle applications, it is recommended that the ballscrew and linear guides are re-greased every six months. High duty cycle applications may require more frequent re-lubrication. Lubrication intervals depend on duty cycle, load and ambient conditions. Inspection of the drivetrain elements may be required to determine the proper lubrication interval. Primatics offers a grease kit that has all the necessary hardware to re-lubricate the ballscrew and linear bearings.

To gain access to component grease ports, remove the Front Top Cover, Front Lower Cover and Rear Top Cover. On the end of each bearing block is a small hole where grease is injected using a syringe. A light film can also be applied the linear bearings when the stage is at one extreme end of travel. After power has been disconnected from the stage, a light film of grease can be smeared along the length of the ballscrew. Cycle the stage back and forth to distribute the grease and wipe off any excess.

The stage should be kept clean and a soft cloth should be used wipe down the stage. Do not use compressed air to spray away dust since this may force dust into crevices.

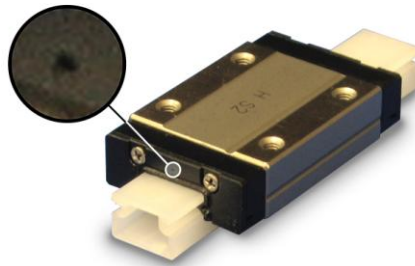

Figure 8-1: Bearing block lubrication port

9) Troubleshooting & Service

9.1) Troubleshooting Help

For further assistance contact the factory:
M-F 8AM to 5PM Pacific Time

Phone:	[541] 791-9678
Fax:	[541] 791-9410
Toll Free:	[888] 754-3111
Web:	www.primatics.com
E-mail:	service@primatics.com

9.2) Service

Should your device require factory service, contact the factory for a Return Materials Authorization (RMA). When inquiring about an RMA please have the following information available:

- Your contact information (name, phone, email, address)
- Unit Serial Number (see Figure 9-1)
- Symptom of problem
- History of troubleshooting steps already taken



Figure 9-1: Unit Serial Number Location