

Frameless Motor
With Ballscrew

100mm Travel PLG110's

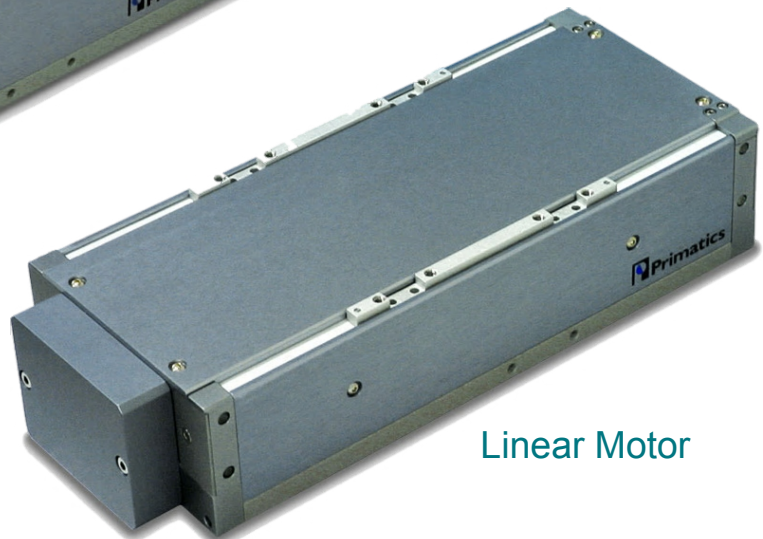

Linear Motor

Features

- Travel to 600mm
- Loads up to 25kg
- Precision Ballscrew Drive or Linear Motor Drive
- Integrated Frameless Servo Motor or NEMA23 Motor Mount
- Internal Linear or Rotary encoder, resolution to 0.1um
- Direct XY stacking
- Failsafe Brake Option
- Protective Belt Option for dirty environments
- Clean Room Options

Overview

Primatics PLG110 Series linear positioning stage is designed for fast integration into any system. Ideal for demanding applications such as inspection, assembly and material handling, the PLG110 offers a variety of configuration options to suit many requirements. Available with either precision ballscrew drivetrain or linear motor drive, both configurations offer excellent performance and reliability.

Features

Standard features include adjustable forward and reverse limit sensors, a home sensor and a protective hard cover. A Linear encoder is standard for the linear motor drive. Models cover travel from 50 to 600mm. Two PLG110's can be directly stacked for XY motion.

Options

5mm lead ballscrew is standard and a 10mm lead is optional. A common ballscrew configuration includes the integrated Frameless Motor option which is a brushless servo motor built directly on the ballscrew. This yields a compact stage relative to the in-line NEMA23 motor mount configuration. An internal rotary encoder or linear encoder (with internal cable management) are standard offerings as is an internal fail-safe brake.

For special environments, models of the PLG110 can be prepared for clean room operation (up to Class 10), or vacuum operation (medium vacuum), or equipped with protective belts and seals for dirty environments.



Dimensions - Frameless Motor

HIGHFLEX CABLE
MOTOR/SIGNAL
AIR PURGE
4mm O.D. TUBING

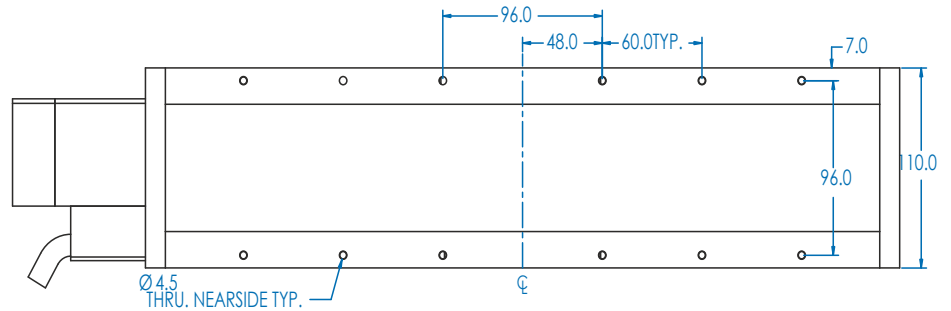
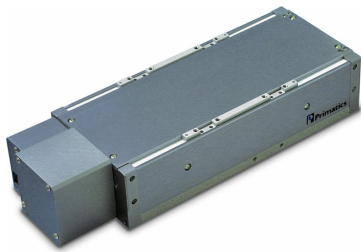
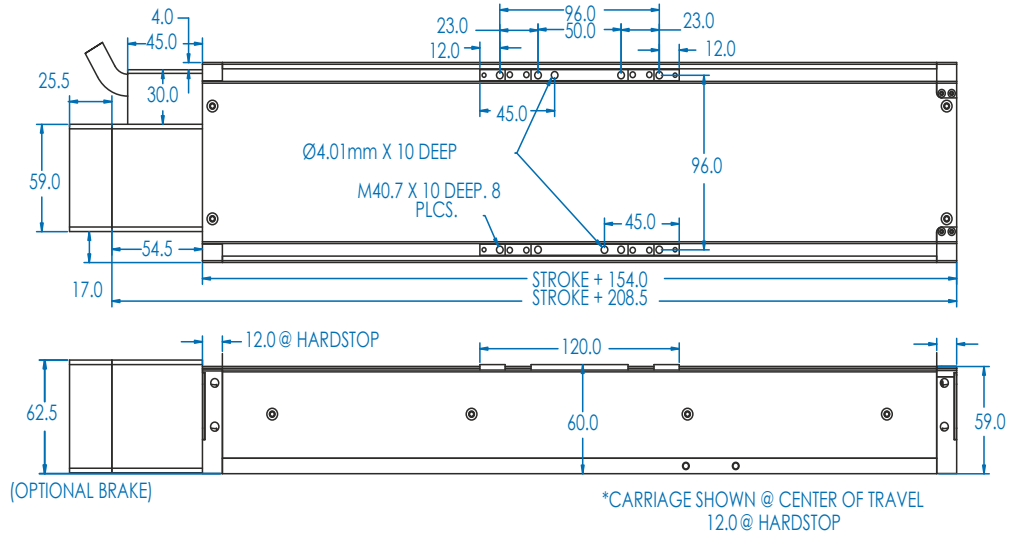
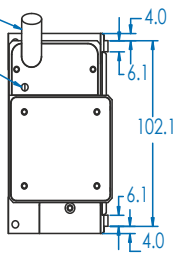

Dimensions - In-Line NEMA 23 Mount

AIR PURGE 4mm
O.D. TUBING

NEMA 23 FACE
Ø38.1 PILOT

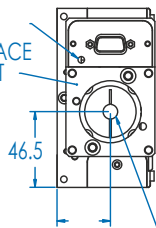

NOTE: STANDARD COUPLING FOR 1/4", 3/8",
8mm, OR 9mm DIAMETER MOTOR SHAFTS.

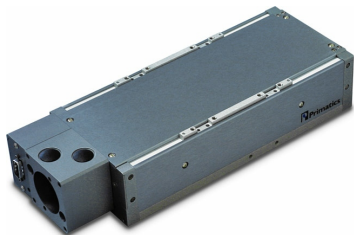
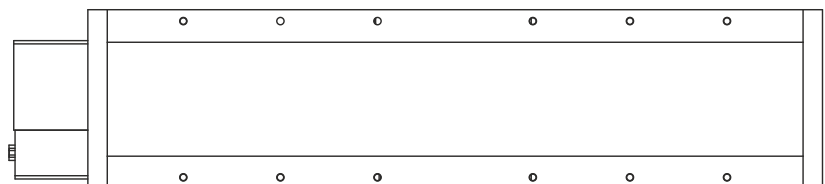
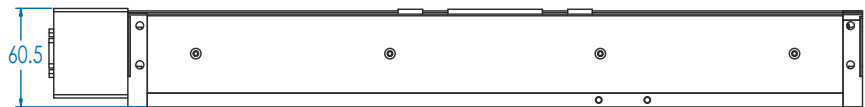
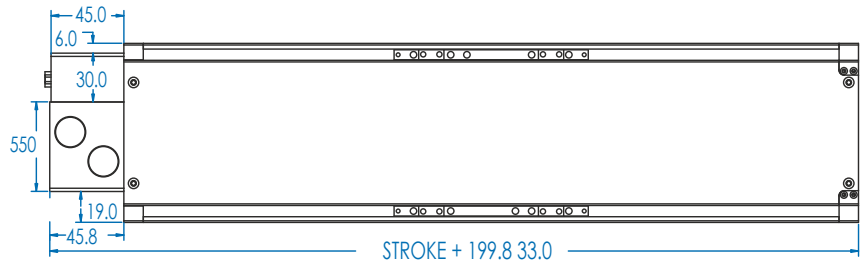

Dimensions - Linear Motor

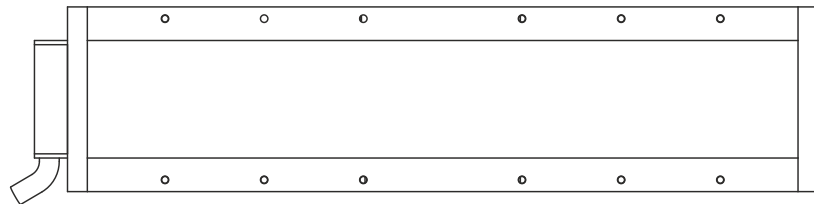
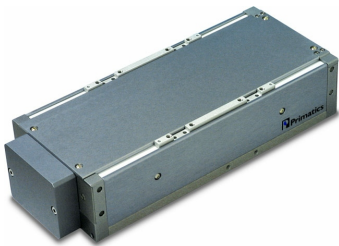
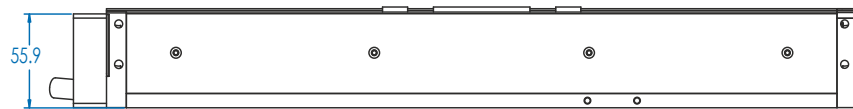
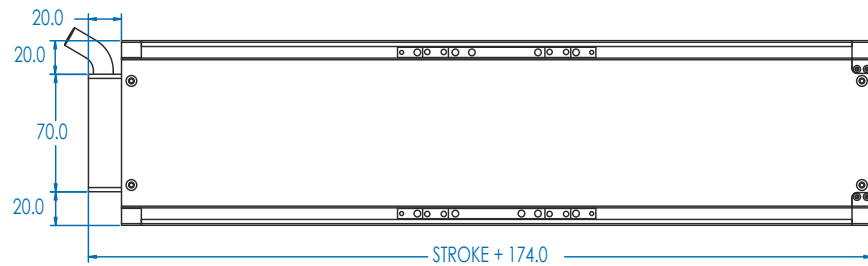
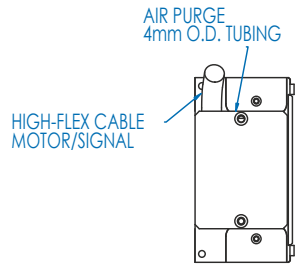

Specifications - Ballscrew Drivetrain

Specifications	Notes	-50	-100	-150	-200	-300	-400	-500	-600
Travel (mm)		50	100	150	200	300	400	500	600
Positional Accuracy Over Total Travel (µm)	1, 2, 3	+/- 6	+/- 6	+/- 7	+/- 9	+/- 12	+/- 14	+/- 16	+/- 18
Positional Accuracy with Linear Encoder (µm)	2	+/- 3	+/- 3.5	+/- 4	+/- 5	+/- 6	+/- 7	+/- 9	+/- 10
Error Mapped Accuracy with E6 Encoder (µm)		+/- 1.4						+/- 2.0	
Error Mapped Accuracy with E4 Encoder (µm)		+/- 1.0						+/- 1.5	
Bi-directional Repeatability (µm)	1, 2, 3	+/- 2.0							
Bi-directional Repeatability with Linear Encoder (µm)	2	+/- 0.5 (E4 encoder); +/- 1.0 (E6 encoder); +/- 2.0 (E2 encoder)							
Straightness of Travel Over Total Travel (µm)	2	+/- 2	+/- 2.5	+/- 3	+/- 3.5	+/- 4	+/- 5	+/- 6	+/- 7
Flatness of Travel Over Total Travel (µm)	2	+/- 1	+/- 1.5	+/- 1.75	+/- 2	+/- 2.5	+/- 3.5	+/- 4.5	+/- 5
Max Speed (mm/sec)	3	300						200	
Direct Loading Capacity (kg)		25							
Axial Loading Capacity (kg)		12							
In-Line Rotational Inertia (kg-m ²)		1.95E-5	2.21E-5	2.48E-5	2.75E-5	3.29E-5	3.84E-5	4.37E-5	4.92E-5
Frameless Motor Rotational Inertia (kg-m ²)		2.13E-5	2.39E-5	2.66E-5	2.93E-5	3.47E-5	4.01E-5	4.55E-5	5.10E-5
Minimum Resolution with Linear Encoder (µm)		0.1							
Pitch Moment Capacity (N-m)		7.5							
Roll Moment Capacity (N-m)		9.7							
Yaw Moment Capacity (N-m)		8.5							
In-Line Stage Weight (kg)		2.8	3.3	3.7	4.2	5.1	6.0	6.9	7.8
Frameless Motor Stage Weight (kg)		3.4	3.9	4.3	4.8	5.7	6.6	7.5	8.4

Notes: 1 - For In-Line / Frameless motor mounts, 1250 line rotary encoder; 2 - Measured 50mm above center of carriage; 3 - 5mm lead ballscrew.
All specifications subject to change without notice.

Specifications - Linear Motor Drivetrain

Specifications	Notes	-100	-200	-300	-400	-500	-600
Travel (mm)		100	200	300	400	500	600
Positional Accuracy Over Total Travel (µm)	1	+/- 3.5	+/- 5	+/- 6	+/- 7	+/- 9	+/- 10
Error Mapped Accuracy with E6 Encoder (µm)		+/- 1.4				+/- 2.0	
Error Mapped Accuracy with E4 Encoder (µm)		+/- 1.0				+/- 1.5	
Bi-directional Repeatability (µm)	1	+/- 0.5 (E4 encoder); +/- 1.0 (E6 encoder); +/- 2.0 (E2 encoder)					
Straightness of Travel Over Total Travel (µm)	1	+/- 2	+/- 3	+/- 3.5	+/- 5	+/- 6	+/- 7
Flatness of Travel Over Total Travel (µm)	1	+/- 1	+/- 2	+/- 2.5	+/- 3.5	+/- 4.5	+/- 5
Max Speed (mm/sec)	2, 3	1000					
Direct Loading Capacity (kg)		25					
Thrust w/o air cooling (N)		14					
Minimum Resolution (µm)		0.1					
Pitch Moment Capacity (N-m)		7.5					
Roll Moment Capacity (N-m)		9.7					
Yaw Moment Capacity (N-m)		8.5					
Stage Weight (kg)		3.4	4.4	5.5	6.5	7.6	8.6

Notes: 1 - Measured 50mm above center of carriage; 2 - Maximum obtainable speed is load and move profile dependent. 3 - 0.1 µm is limited to 300mm/sec
All specifications subject to change without notice.

Stage Information

Stage Information	PLG110...D1	PLG110...D2	PLG110...D3	PLG110..D4
Carriage Mass (kg)	0.7		0.5	0.6
Maximum Acceleration, unloaded (G's)	1.0		3.0	
Maximum Breakaway Torque/Force	0.15 N-m	0.23 N-m	1.0 N	
Maximum Running Torque/Force	0.13 N-m	0.20 N-m	0.9 N	
Maximum Motor Bus Voltage (VDC)	170		90	
Length of Cable (mm)	350			
Life at Listed Specification (km)	5000			

Carriage Stiffness

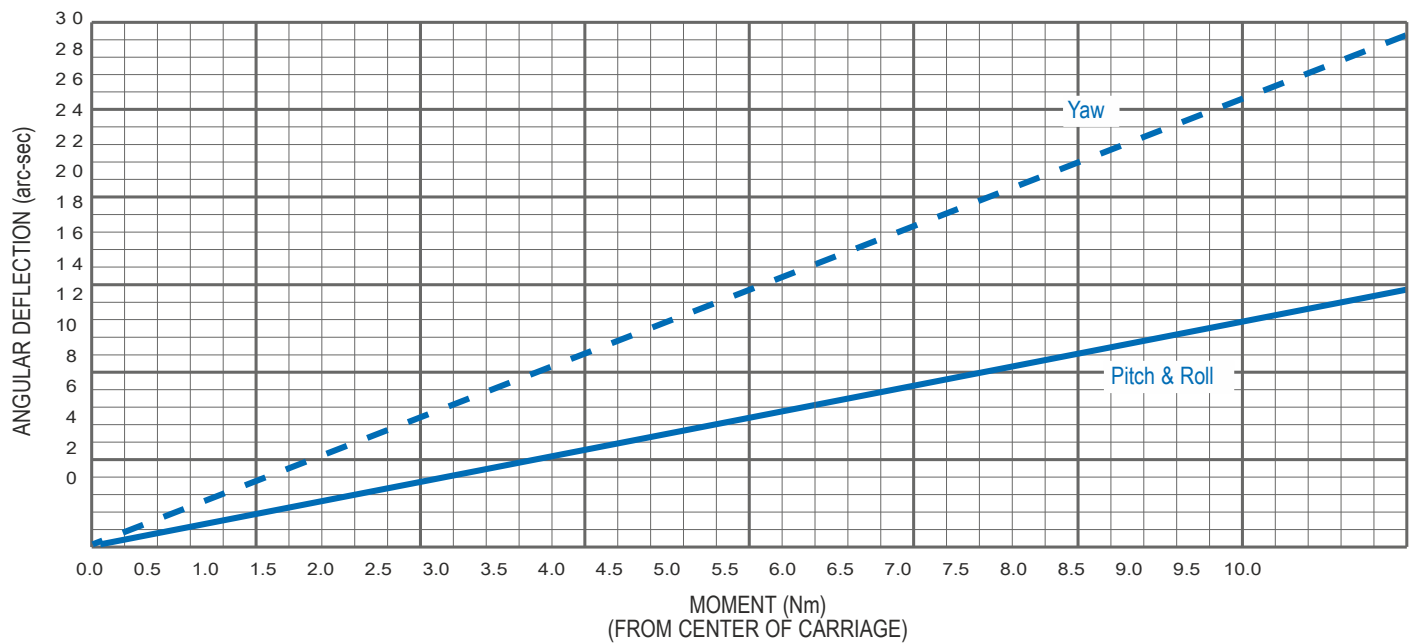

Tabletop Accessory

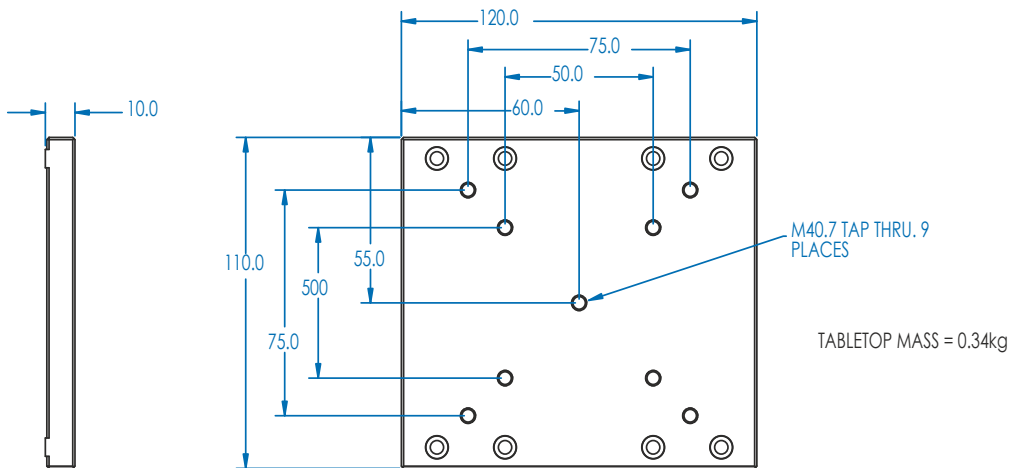

Motor Data

Parameter	Notes	M1-2 (NEMA 23 Rotary)	M4-4 (Frameless)	D 3 Linear Single Stack	D4 Linear Double Stack
Motor Type		Brushless Servo			
Continuous Torque or Force	1	0.46 N-m	0.23 N-m	8.4 N	16.2 N
Continuous Current (Arms)	1	3.9	2.4	1.3	1.2
Peak Torque or Force	2	0.9 N-m	2.95 N-m	41.8 N	83.3 N
Peak Current (Arms)	2	7.5	30	6.3	6.3
Torque or Force Constant		0.12 N-m/Arms	0.1 N-m/Arms	6.7 N/Arms	13.2 N/Arms
Back EMF Constant		11.7 V/Krpm	10.3 V/Krpm	6.7 V/m/s	13.2 V/m/s
Winding Resistance (ohms)		0.62	1.6	3.2	6.4
Winding Inductance (mH)		0.92	1.5	15.9	4.0
Thermal Resistance (C/W)		1.7	2.8	5	2.6
Poles		8	6	N/A	
Rotor Inertia (kg-m ²)		1.41E-5	7.86E-6	N/A	
Magnetic Pitch (mm)		N/A		60.96	
Hall Sensor Power		5 to 24VDC, 50mA			
Hall Outputs		Open collector, current sinking, 20mA max			
Weight (kg)		0.93	0.6	N/A	

Notes: 1 - At 25°C maximum temperature rise; 2 - At 10% duty cycle and 1 second maximum. All specifications subject to change without notice.

Encoder Data

Parameter	M1-2 NEMA23 Rotary	Internal Rotary	Linear Encoder
Input Power (VDC)	5VDC +/- 5%, 150mA		
Output	Square wave differential line driver		
Index	Synchronized pulse, duration equal to one resolution bit		
Resoluton	4000 lines/rev	See Ordering Option	See Ordering Option
Max Speed imposed by encoder (mm/sec)	500	500	2600 (E2 encoder) 1000 (E5, E9, E0 encoder) 600 (E6 encoder) 300 (E4 encoder)

Brake Data

Parameter	Value
Input Power (VDC)	24VDC, 0.5A
Holding Force, 5mm lead (kg)	12.0

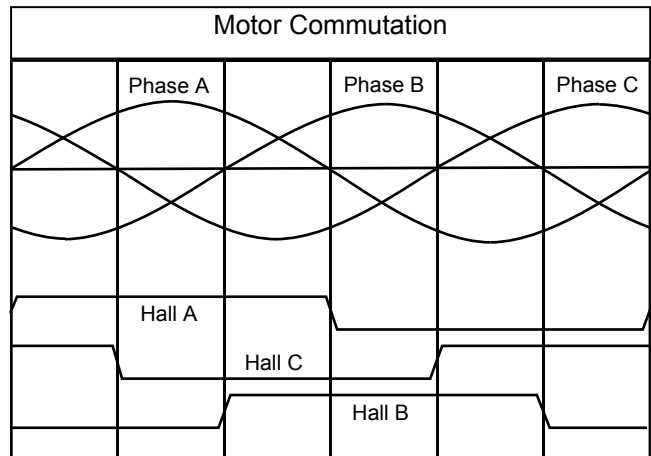

Connectors

In-Line, no internal encoder	
Connector Type: Dsub, 9 pins Mates with Dsub, 9 sockets	
Pin	Function
1	Limit Power (12-24VDC)
2	Limit Power Return and Signal Common
3	Forward Limit - Activates at Full Forward Travel
4	Reverse Limit - Activates at Full Reverse Travel
5	Home
6	Brake+ (with optional brake)
7	Brake- (with optional brake)
8	No connection
9	No connection

In-Line, with internal encoder		
Connector Type: High Density Dsub, 15 pins Mates with High Density Dsub, 15 sockets		
	Without Brake	With Brake Option
Pin	Function	
1	Limit Power (12-24VDC)	
2	Limit Power Return and Signal Common	
3	Forward Limit - Activates at Full Forward Travel	
4	Reverse Limit - Activates at Full Reverse Travel	
5	Home	
6	Not used	Brake+
7	Encoder Shield	Brake-
8	Encoder 5V	
9	Encoder Power Return	
10	Encoder A+	
11	Encoder A-	
12	Encoder B+	
13	Encoder B-	
14	Encoder I+	
15	Encoder I-	

Motor Included (NEMA23, Frameless, Linear)	
Connector: Cannon 192926-0480 Size 20, 28 pins	
Pin	Function
A	Motor Phase A
B	Motor Phase B
C	Motor Phase C
D	Motor Shield
E	Encoder 5V
F	Encoder A+
G	Encoder A-
H	Encoder B+
J	Encoder B-
K	Encoder Shield
L	Limit Power (12-24VDC)
M	Limit Return and Signal Common
N	Home
P	Brake+ (with optional brake)
R	Brake- (with optional brake)
S	Signal Shield
T	Hall V+
U	Hall V-
V	Encoder Power Return
W	Encoder I+
X	Encoder I-
Y	Forward Limit - Activates at Full Forward Travel
Z	Reverse Limit - Activates at Full Reverse Travel
a	KEY
b	Hall A
c	Hall B
d	Temp switch (Frameless and Linear only)
e	Hall C

PLG110 Model Configuration

Example: **PLG110AL 0200P D1 H1 L1 C1 M4-4 E2 B1 P2 - M**

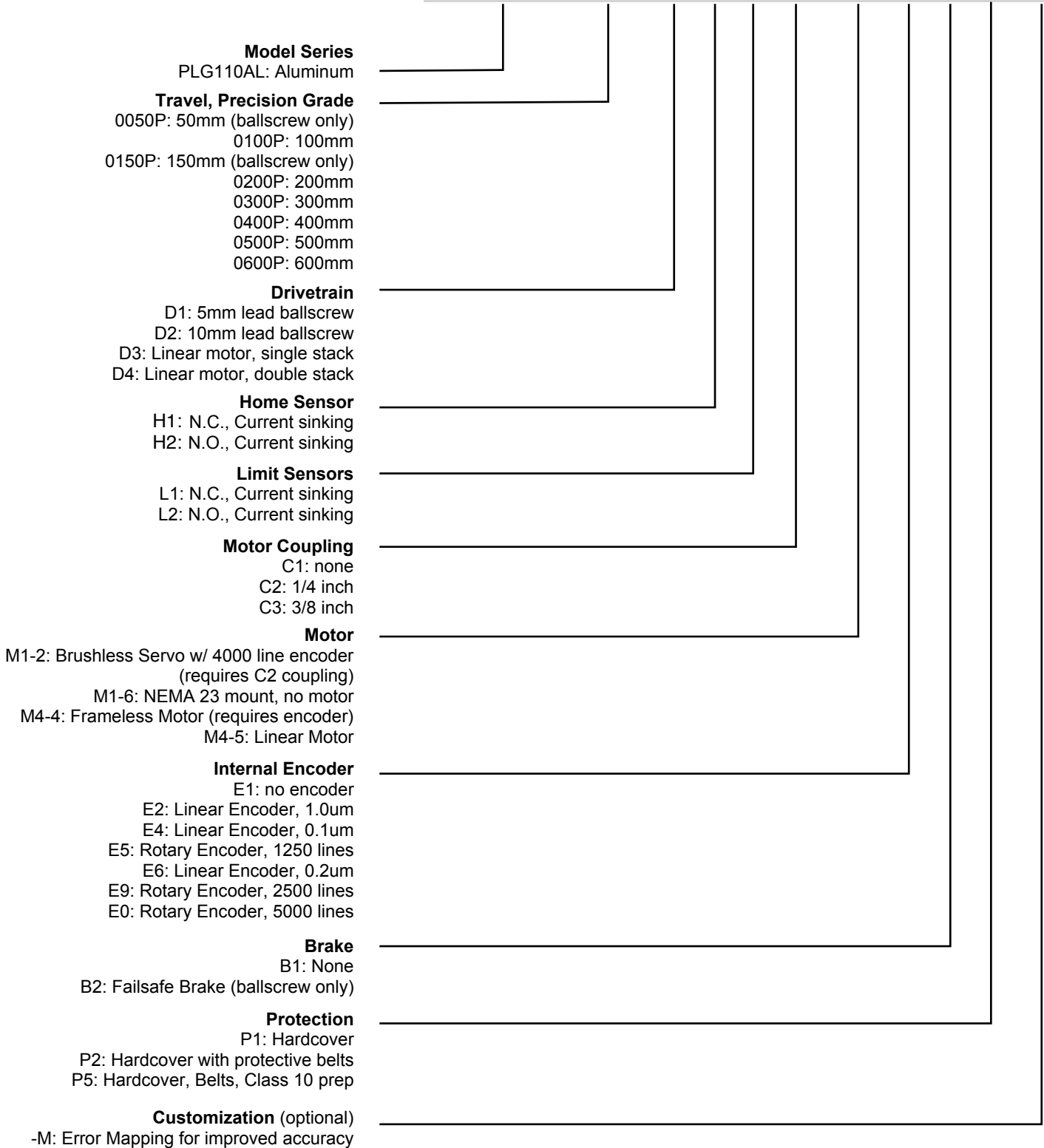

Not all configurations are valid - consult factory for assistance